

Service Manual

Turntable System

SL-5300 (XGE), (E) (X), (XAL) (XG), (XGF) / SL-5310 (E), (XG)

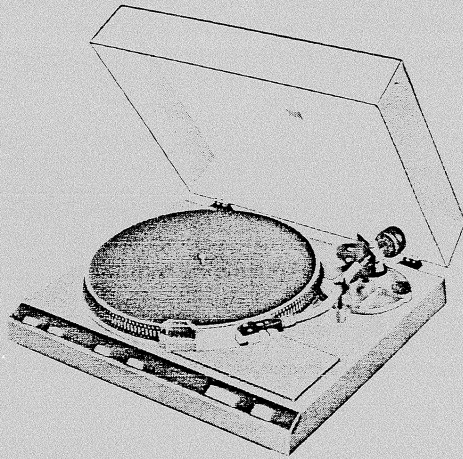

- The model SL-5300 (X) is available in Asia, Latin America, Middle East and Africa only.
- The model SL-5300 (XAL) is available in Australia only.
- The model SL-5300 (XGE) is available in United Kingdom only.
- The model SL-5300 (E) is available in Scandinavia only.
- The model SL-5300 (XG) is available in European only.
- The model SL-5300 (XGF) is available in France only.
- The model SL-5310 (E) is available in Scandinavia only.
- The model SL-5310 (XG) is available in European only.

- SL-5300 is of silver finish.
- SL-5310 is of black finish.

SPECIFICATIONS (Specifications are subject to change without notice for further improvement)

General

Power supply:	~ 110-120/220-240V, 50 or 60 Hz
Power consumption:	12 W
Dimensions: (W x H x d)	43.0 x 13.0 x 37.5 cm (16.59/64x5.7/64x14.49/64 inches)
Weight:	7.1 kg (15.7 lb)

Turntable section

Type:	Direct Drive Automatic Turntable System (Auto-start, Auto-return, Auto-stop Repeat play and Manual play)
Drive method:	Direct drive
Motor:	Brushless DC motor
Turntable platter:	Aluminum die-cast, 30.4 cm (12")
Turntable speeds:	33-1/3 and 45 rpm.
Pitch controls:	Individual adjustment controls, ±6% adjustment range 1 kg·cm (0.87 lb·in)
Starting torque:	90° or 1/4 rotation to 33-1/3
Build-up characteristics:	
Speed fluctuation due to load torque:	0% within 0.9 kg·cm (0.78 lb·in) (even at a stylus pressure of 180 g)
Speed drift:	Within ±0.002%
Wow and flutter:	0.025% WRMS (JIS C5521) ±0.035% peak (IEC 98A Weighted)
Rumble:	-56 dB (IEC 98A Unweighted) -78 dB (IEC 98A Weighted)

Tonearm section

Type:	Universal tubular arm, static- balanced type
Effective length:	230 mm (9-1/16")

Overhang:	15 mm (19-32")
Friction:	Within 7 mg (horizontally and vertically)
Effective mass:	12 g (without cartridge)
Tracking error angle:	Within 2°32' (at the outer groove of 30 cm (12") record) Within 0°32' (at the inner groove of 30 cm (12") record)
Offset angle:	22°

Adjustable stylus pressure range:	0 to 2.5 g (stylus pressure direct reading type)
Cartridge weight range:	6 to 9.5 g 13.5 to 17 g (including headshell)
(with shellweight):	3 to 6.5 g 10.5 to 14 g (including headshell)
Headshell weight:	7.5 g

Cartridge section (for set with cartridge)

Type:	Moving magnet
Frequency response:	20 Hz to 25 kHz
Output voltage:	3.5 mV at 1 kHz 5 cm/sec. zero to peak lateral velocity (10 mV at 1 kHz, 10 cm/sec. zero to peak 45° velocity [DIN 45500])
Channel separation:	25 dB at 1 kHz
Channel balance:	Within 2 dB at 1 kHz
Compliance (dynamic):	12×10^{-6} cm/dyne at 100 Hz
Stylus pressure:	1.25 ± 0.25 g (12.5 ± 2.5 mN)
Load impedance:	47 k Ω to 100 k Ω
Weight:	6.0 (cartridge only)
Replacement stylus:	EPS-206ED

TECHNISCHE DATEN (Änderungen der technischen Daten vorbehalten.)

Allgemeine Daten

Netzspannung: ~110–120/220–240 V, 50/60 Hz Wechselstrom
Leistungsaufnahme: 12 W
Abmessungen: 43,0 x 13,0 x 37,5 cm (B x H x T)
Gewicht: 7,1 kg

Plattenspielerenteil

Typ: Automatisches Plattenspielerensystem mit Direktantrieb, (Auto-Start, Auto-Rückkehr, Auto-Stop, wiederholtes Abspielen und manuelles Abspielen)
Antrieb: Direktantrieb
Motor: Kollektorloser Gleichstrommotor
Plattenteller: Aluminium-Spritzguß 30,4 cm Ø
Plattenteller-Drehzahlen: 33-1/3 und 45 U/min
Geschwindigkeits-Feineinstellung: Für jede Geschwindigkeit gesondert, mittels Einsteller, ±6% Einstellbereich 1 kg·cm
Anlaufdrehmoment:
Drehzahl-Hochlaufdauer: 90° oder 1/4 Umdrehung bei 33-1/3 U/min
Drehzahl-Schwankung wegen Lastschwankungen: 0% innerhalb 0,9 kg·cm (sogar bei einer Auflagekraft von 180 g)
Drehzahl-Abweichung: Innerhalb ±0,002%
Gleichlaufschwankungen: 0,025% WRMS (JIS C5521) ±0,035% (IEC 98A bewertet)
Rumpel-Fremdspannungsabstand: –56 dB (IEC 98A unbewertet)
Rumpel-Geräuschspannungsabstand: –78 dB (IEC 98A bewertet)

Tonarmteil

Typ: Universal-Rohrtonarm, statisch ausbalanciert

Effektive Länge: 230 mm
Überhang: 15 mm
Mechanischer Widerstand: weniger als 7 mg (horizontal, vertikal)
Effektive Masse: 12 g (ohne Tonabnehmer)
Spurfehlwinkel: Innerhalb 2°32' (bei der äußeren Rille einer 30 cm-Schallplatte)
 Innerhalb 0°32' (bei der inneren Rille einer 30 cm-Schallplatte)
 22°
Kröpfungswinkel:
Auflagedruck-Einstellbereich: 0 ~ 2,5 g (direkt ablesbare Einstellung)
Zulässiger Tonabnehmer Gewichtsbereich: 6 ~ 9,5 g
 13,5 ~ 17 g (einschließlich Tonarmkopf)
(mit Tonarmkopf-Gewicht): 3 ~ 6,5 g
 10,5 ~ 14 g (einschließlich Tonarmkopf)
Tonarmkopf-Gewicht: 7,5 g

Tonabnehmerteil (für Gerät mit Tonabnehmer)

Typ: Magnetischer Tonabnehmer
Frequenzgang: 20 Hz to 25 kHz
Ausgangsspannung: 3,5 mV bei 1 kHz
 5 cm/sec Null-zu Spitze, lateral (10 mV bei 1 kHz 10 cm/sec Null-zu Spitze, 45° [DIN 45500])
Kanaltrennung: 25 dB bei 1 kHz
Kanalabweichung: Innerhalb 2 dB bei 1 kHz
Nachgiebigkeit (dynamisch): 12 x 10⁻⁶ cm/dyn bei 100 Hz
Auflagekraft: 1,25 ± 0,25 g (12,5 ± 2,5 mN)
Impedanz: 47 kΩ bis 100 kΩ
Gewicht: 6,0 g (ohne Tonarmkopf)
Ersatznadel: EPS-206ED

CARACTERISTIQUES TECHNIQUES (Les spécifications sont susceptibles d'être modifiées préavis.)

Généralités

Alimentation: Alternatif 110–120/220–240 V, 50 ou 60 Hz
Consommation: 12 W
Dimensions: 43,0 x 13,0 x 37,5 cm (L x H x P)
Poids: 7,1 kg (15,7 lb)

Platine de lecture

Typ: Système de platine automatique à entraînement direct, (Auto-démarrage, Auto-retour, Auto-arrêt, Audition répétée et Audition manuelle).
Système d'entraînement: Entraînement direct
Moteur: Moteur C.C. sans balais
Plateau de lecture: Aluminium moulé sous pression
 Diamètre 30,4 cm
Vitesses de rotation: 33-1/3 et 45 t/p.m.

Commandes de précision de la vitesse: Commandes de réglage individuelles; plage de réglage ±6%
 1 kg·cm

Couple de démarrage:

Caractéristiques d'augmentation: 90° ou 1/4 de rotation à 33-1/3 t/p.m.
Variation de vitesse due au couple de charge: 0% en deçà de 0,9 kg·cm (même à une pression de la pointe de 180 g)
Déviations du nombre de tours: En deçà de ±0,002%

Pléurage et scintillement: 0,025% de valeur efficace (JIS C5521) ±0,035% de crête (IEC 98A Pondéré)
Ronflement: –56 dB (IEC 98A Non Pondéré) –78 dB (IEC 98A Pondéré)

Bras de lecture

Typ: Bras tubulaire universel, de type à équilibrage statique
Longueur effective: 230 mm
Porte-à-faux: 15 mm

Frottement: Moins de 7 mg (horizontal et vertical)
Massa réelle: 12 g (sans la cellule pick-up)
Angle d'erreur de piste: En deçà de 2°32' (au sillon extérieur d'un disque de 30 cm)
 En deçà de 0°32' (au sillon intérieur d'un disque de 30 cm)
 22°

Angle de décalage:
Plage de réglage de la pression d'appui: 0 à 2,5 g (type à lecture directe de la pression d'appui de la pointe)

Gamme de poids de la cellule pick-up utilisable: 6 à 9,5 g
 13,5 à 17 g (y compris la coque porte-cellule)

(avec contrepoids de la cellule): 3 à 6,5 g
 10,5 à 14 g (y compris la coque porte-cellule)

Poids de la coquille porte-cellule: 7,5 g

Cellule pick-up (pour appareil avec cellule pick-up)

Typ: Aimant mobile
Réponse en fréquence: 20 Hz à 25 kHz
Tension de sortie: 3,5 mV à 1 kHz
 5 cm/sec., zéro à vitesse latérale de crête (10 mV à 1 kHz, 10 cm/sec., zéro à vitesse 45° de crête [DIN 4500])
 25 dB à 1 kHz

Séparation de canal: En deçà de 2 dB à 1 kHz
Equilibrage des canaux: 12 x 10⁻⁶ cm/dyne à 100 Hz
Elasticité (dynamique):

Pression de la pointe de lecture: 1,25 ± 0,25 gramme (12,5 ± 2,5 mN)
Impédance de charge: 47 kΩ à 100 kΩ
Poids: 6,0 grammes (cellule seule)
Pointe de lecture de remplacement: EPS-206ED

■ DISASSEMBLY PROCEDURE

How to remove bottom board

1. Remove head shell and turntable.
2. Secure arm with arm clamp.
3. Turn the set upside-down taking care not to damage dust cover.
4. Remove bottom board set-screws (7 pcs).

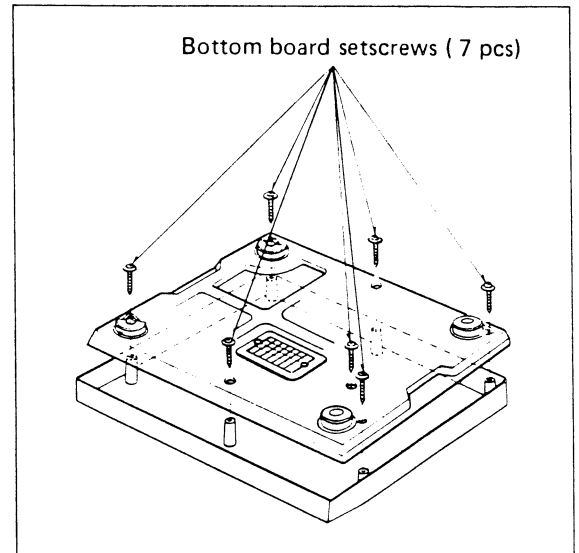

How to remove panel

1. Remove 6 front knobs.
2. Remove bottom board as shown above.
Note. Be careful not to drop washers attached to operation knobs and cueing knobs.
3. Remove panel and select switch plate.
4. Remove 6 claws of panel as illustrated.

Push in the direction of the arrow.

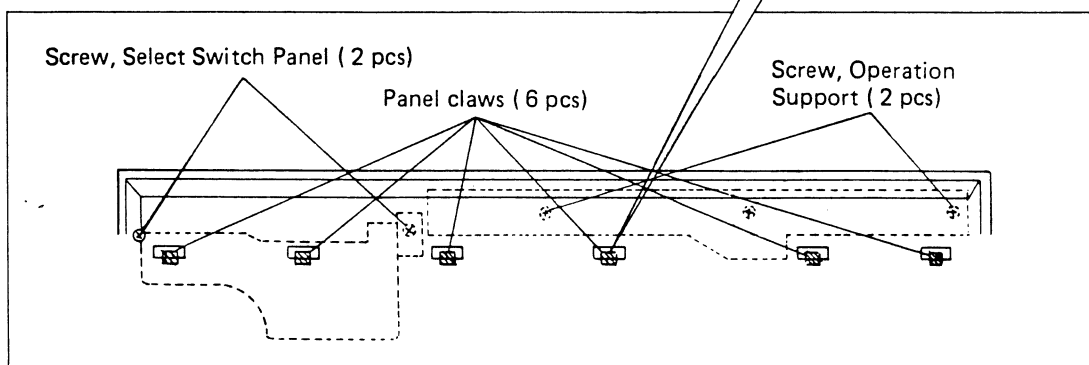
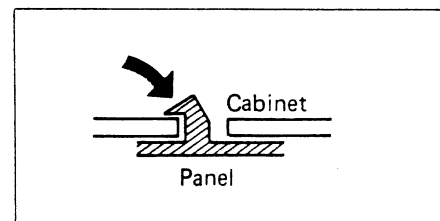

How to remove hinge

Turn the set upside-down and then insert screwdriver between hinge and cabinet. Deform the cabinet as shown by the arrow in the illustration.

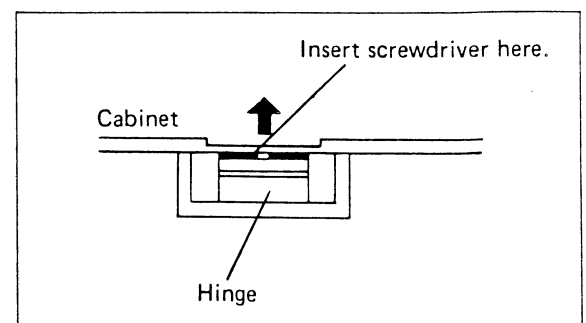

Remarks:

For the disassembly of parts (mechanical board, circuit board, etc.) other than the above, refer to the parts arrangement and development diagrams provided in this manual.

■ PARTS ARRANGEMENT DIAGRAM

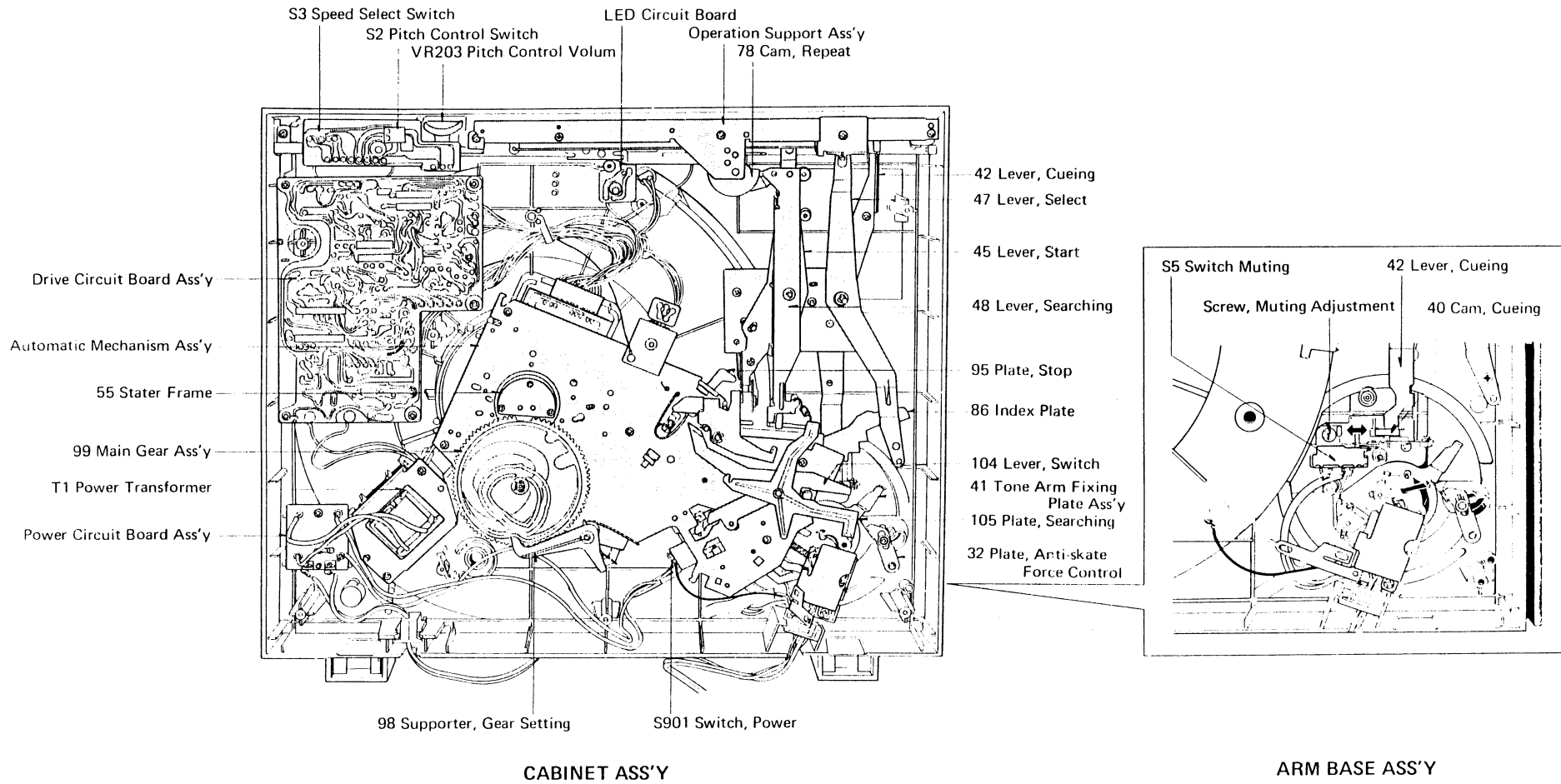

■ **PARTS IDENTIFICATION**

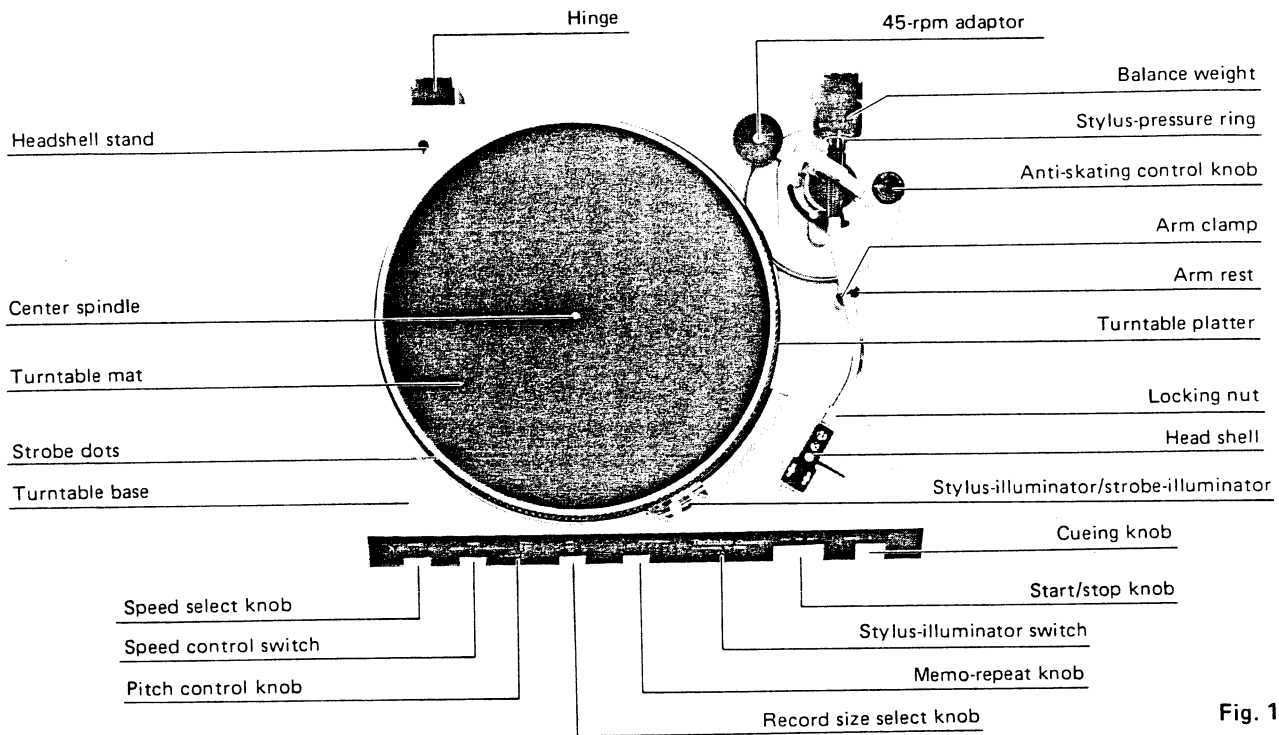

Fig. 1

■ **FEATURES**

High performance electronic circuit and full-cycle detection FG for quartz phase-locked control of integral structure superior in rotational characteristics

Based on an electronic circuit composed of 3 kinds of highly integrated ICs developed for the SL-1300MK2 series and the full-cycle (360°) detection FG, the quartz phase locked control system with a crystal oscillator as its standard oscillator has been adopted. For utilization of high accuracy crystal oscillation, the detection range is effected through 360° by means of the full-cycle detection FG of the motor stator for detection of revolutions, with a consequent extremely stable rotational accuracy.

Due to the employment of the integral structure, high torque DD motor, the starting time is practically instantaneous at 0.7 second (1/4) revolution. Moreover, through the quartz phase locked control system employed, speed deviation is 0 up to a stylus pressure of 180 g, while a pitch control of ±6% is possible.

Double-TNRC vibration-damping construction

The newly developed acoustic material* TNRC, which is high in vibration damping and superior in attenuation characteristics has been employed in the cabinet, while the base has another thick and heavy TNRC base which has been adopted for the SL-1300MK2 series.

Double TNRC construction is designed based on Technics non-resonance concept.

*TNRC – Technics Non-Resonance Compound

Equipped with a stylus illuminator (stylus tip lighting) that facilitates selection of music even in a dark place

3 row strobe dots capable of fine adjustments of +3.3% and -3.3%

Low-mass, gimbal-suspension tonearm with an arm friction of 7 mg and a muting circuit incorporated

The gimbal-suspension tonearm unique to Technics has descended from the tonearms for the SL-1300MK2 series and is extremely sensitive with an arm friction of 7 mg (horizontal and vertical) and is of a low mass design having an effective mass of only 12 g. For using a high compliance cartridge, the low range resonance frequency is set in the vicinity of 10 Hz. Furthermore, since a muting mechanism is adopted for eliminating noises during the descent or ascent stylus tip to and from the record.

All Front-Panel Controls

The advancement to complete front-panel control marks a big step forward in turntable operation, not only because of the greater convenience, but also because of the greater protection from dust, as the dust cover can stay closed.

Tonearm Cueing Controlled from Front Panel

The tonearm is raised and lowered softly by a viscous-damped cueing lifter. Even with the dust cover closed, a cueing can be easily performed as the control is located on the front panel.

Fully-Automatic Operation

All operations in the SL-5300 are completely automatic, yet mechanical movements are accurate and silent. Full protection to records and stylus tip is assured. With the memo-repeat feature, favorite records may be repeated up to six times, or indefinitely.

Light, Aluminum Diecast Headshell

■ HOW TO OPERATE

Manual play of record

1. Place a record on the turntable mat.
2. Set the speed select knob to the desired record speed.
(See Fig. 2)

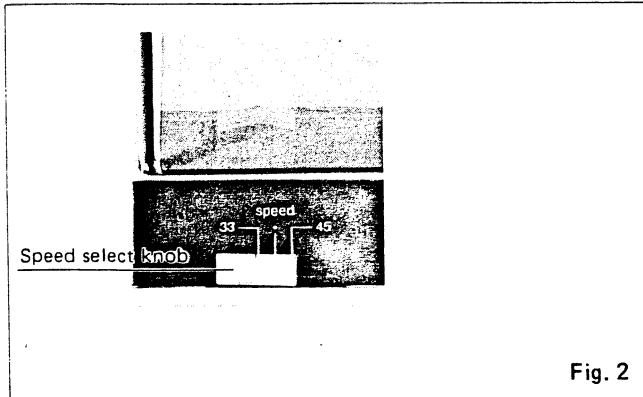

Fig. 2

3. Remove the stylus protector, if your cartridge has a detachable one.
4. Release the arm clamp.
5. Set the cueing knob to the "▼" position. (See Fig. 3)
6. Move the tonearm over the record and set the cueing knob to the "▼" position. (See Fig. 4)

The tonearm will descend slowly onto the record and play will begin. When the tonearm is moved toward the record, the power is turned on and the turntable platter will start rotating.

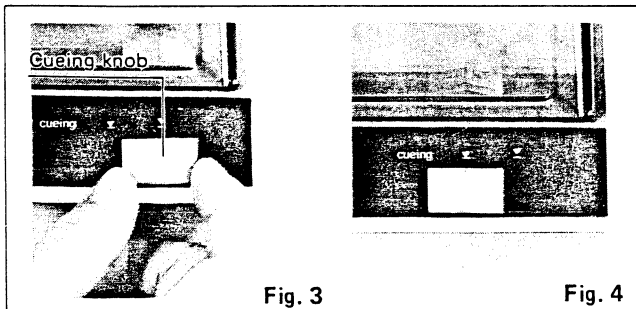

Fig. 3

Fig. 4

7. When play is finished, the tonearm will automatically return to the arm rest (auto-return), and the turntable platter will stop rotation. The turntable platter will continue to rotate briefly due to its own inertia.
If the unit is not to be used for some time, set the speed select knob to the neutral "•" position.
Attach the stylus protector again, if you have one, to guard the stylus tip from damage.

When you play a 45-rpm record with a large center hole

Place the 45-rpm adaptor on the center spindle. Set the speed select knob to the "45" position.

Automatic play

1. Set the speed select knob in the same manner as in manual play and release the arm clamp.
2. Set the record size select knob to the diameter of the record (7" [17 cm], 10" [25 cm], or 12" [30 cm]) you wish to play. (See Fig. 5)

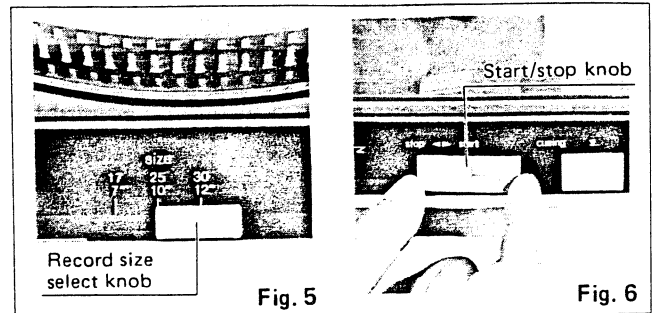

Fig. 5

Fig. 6

3. Set the start/stop knob to the "start" position. (See Fig. 6). (In this case, the "memo-repeat" knob will move to "1" first, but it will automatically return to the "0" position after play has begun.) The tonearm will move automatically over the lead-in groove and descend slowly onto the record (auto-start). Play will begin.
4. When play has finished, the tonearm will automatically return to the arm rest (auto-return).

Repeat play of a record

1. Set the "memo-repeat" knob to the desired number of times you wish to play.
"R" position enables you to repeat play continuously.

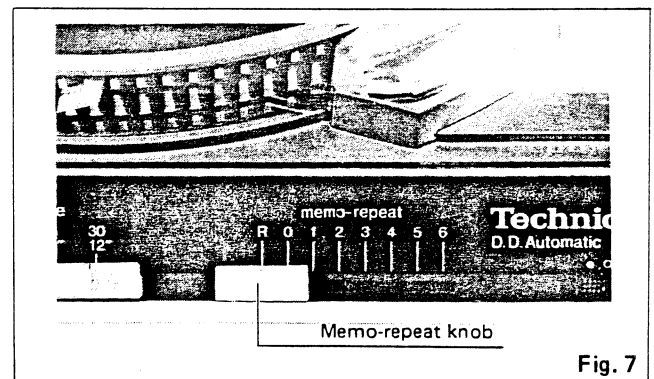

Fig. 7

Note:

The "memo-repeat" knob may be set to a desired number, except during automatic start or automatic return cycle.

If you start play manually while the "memo-repeat" knob is set to a number, there will be an additional repeat play.

2. Start play in the same way as for automatic play.

How to stop play

Set the start/stop knob to the "stop" position.

The tonearm automatically returns to the arm rest, and the turntable stops rotating.

Of course, the unit will automatically shut off even when the tonearm is manually returned to its arm rest directly.

Note:

Before you operate the start/stop knob, make sure that the "memo-repeat knob is set at the "0" position

If this knob is set at any position other than "0", the repeat play is continued by the number of times indicated, even if you set the start/stop knob to the "stop" position.

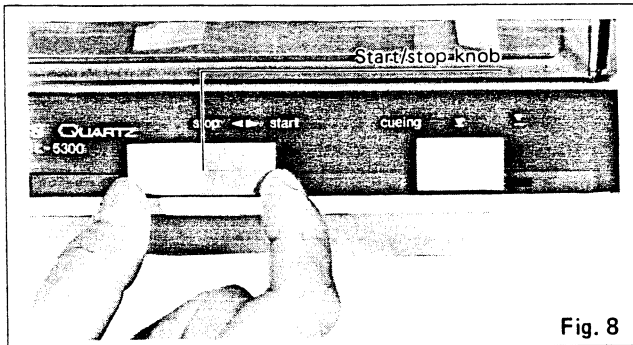

Fig. 8

How to suspend play

Set the cueing knob to the "▼" position.

The stylus tip of the cartridge will be lifted from the record.

If the unit is not to be used for some time

Secure the tonearm with the arm clamp.

Attach the stylus protector, if your cartridge has one, to guard the stylus from damage.

Close the dust cover.

About on/off of the stylus illuminator (See Fig. 9)

The unit is equipped with a stylus illuminator for lighting the stylus tip during performance as well as a strobe illuminator (LED).

When the switch for the stylus illuminator is set to the "•" position, the stylus illuminator and strobe illuminator are lit upon rotation of the turntable.

If the stylus illuminator is not required, turn the stylus illuminator switch to the "0" position.

Then, the lamp for stylus tip illumination goes out and only the LED for the strobe illuminator is lit.

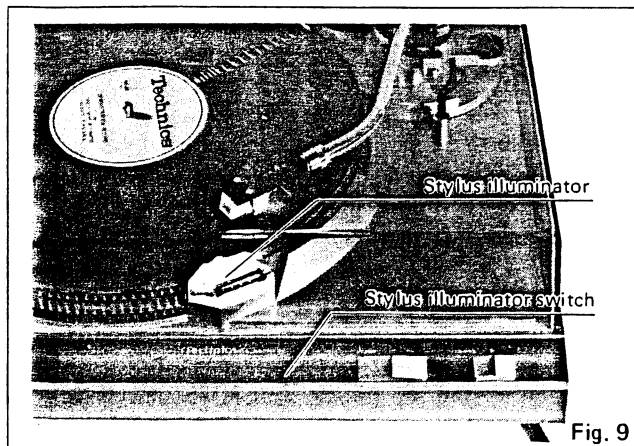

Fig. 9

■ ADJUSTMENTS

Adjustments of horizontal zero (0) balance and stylus pressure

1. Before adjusting horizontal zero (0) balance, check the following:

Make sure that the speed select knob is in the "•" (neutral) position.

Make sure that the cueing knob is in the "▼" position.

Make sure that the anti-skating control knob is at "0" position.

Make sure that the "memo-repeat" knob is in the "0" position.

2. Remove the stylus protector, if your cartridge has a detachable one. Be careful not to touch your fingers to the stylus tip.

3. Release the arm clamp and lift the tonearm from the arm rest to free it.

Turn the entire balance weight clockwise (indicated by the arrow "A") or counterclockwise (indicated by the arrow "B") until the tonearm is approximately balanced horizontally (floats freely). (See Figs. 10 and 11.)

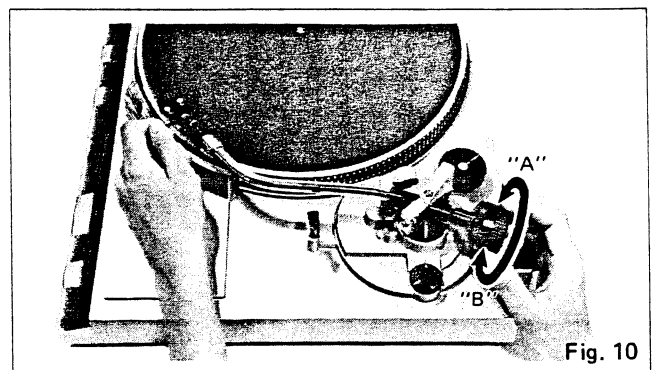

Fig. 10

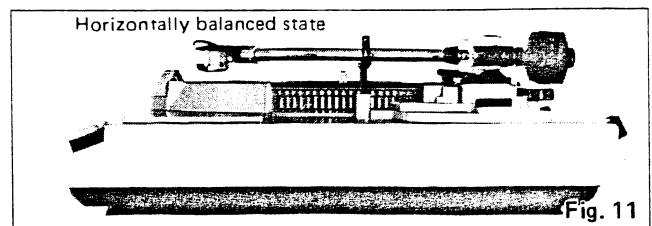

Fig. 11

Note:

During the adjustment of the horizontal zero (0) balance, be careful that the stylus tip of the cartridge does not contact the turntable mat or turntable base.

4. After the tonearm is horizontally zero (0) balanced, temporarily refasten the tonearm with the arm clamp.

5. Hold the balance weight stationary with one hand as shown in the picture, and rotate only the stylus-pressure ring to bring the numeral "0" of the ring into alignment with the center line on the tonearm rear shaft.

The adjustment of the horizontal zero (0) balance is now completed.

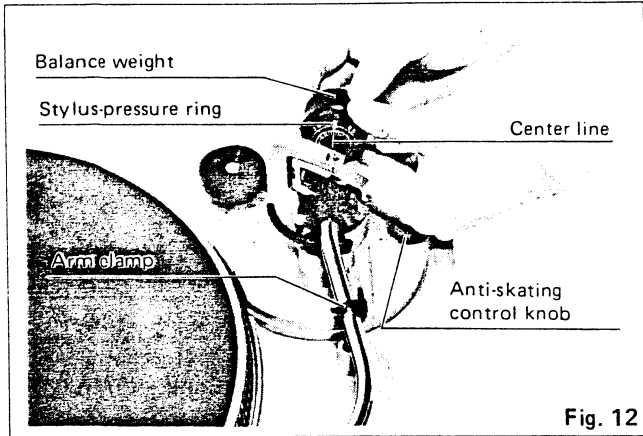

Fig. 12

6. After adjusting the horizontal zero (0) balance, turn the balance weight clockwise in the direction of the arrow and align to the correct stylus pressure. (See Fig. 13.) (Follow the cartridge manufacturer's recommendation.) As the stylus-pressure ring moves in step with the balance weight proper stylus pressure can be selected by directly reading the graduated ring.

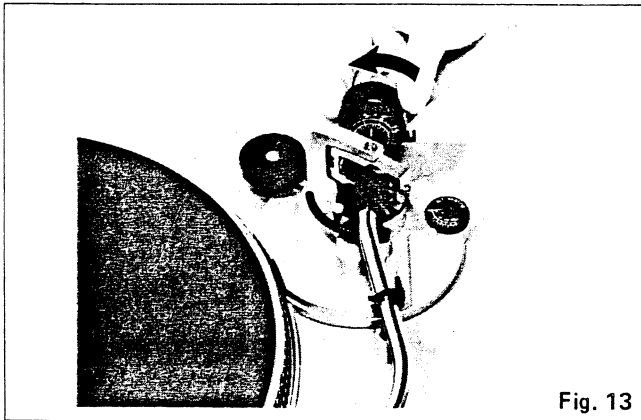

Fig. 13

Note:

Set the stylus pressure to the maximum recommended value for your cartridge in cases where the record has an extremely high recording level or where the unit is operated in a room at low temperature, or in places in which the unit is subjected to vibrations.

Adjustment of anti-skating control

Set the anti-skating control knob to the same value as the stylus pressure. (See Fig. 14.)

Note:

When a cartridge with integral dust brush is used, follow the cartridge manufacturer's recommendation for adjusting both stylus pressure and anti-skating force.

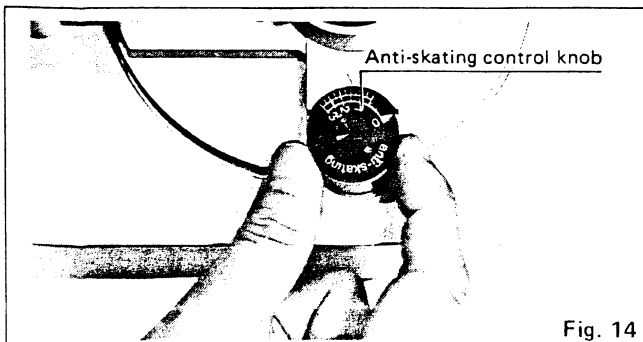

Fig. 14

Adjustment of arm-lift height (See Figs. 15 and 16)

The arm-lift height (distance between the stylus tip and record surface when queuing knob is at the "▼" position) has been adjusted at the factory before shipment to approximately 5 to 10 mm.

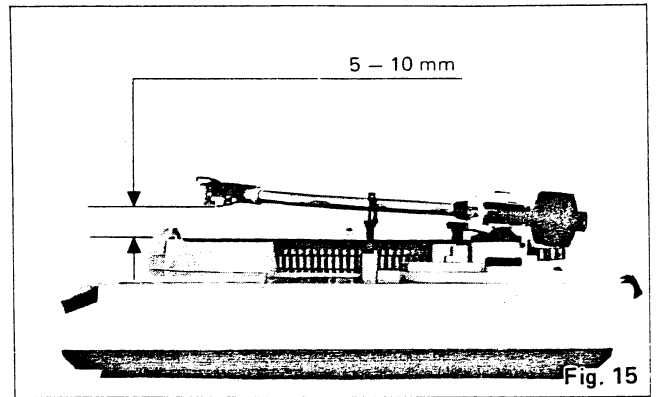

Fig. 15

For using different cartridges available on the market or when further adjustments are particularly necessary, make adjustment as follows:

1. Set the speed select knob to the "•" position to prevent rotation of the turntable platter.
2. Move the tonearm toward the center spindle. Attach the stylus protector, if available, to guard the stylus tip from damage.
3. Turn the adjustment screw clockwise or counterclockwise, while pushing the arm lift down.
 - Clockwise rotation
—distance between the record and stylus tip is reduced.
 - Counterclockwise rotation
—distance between the record and stylus tip is increased.

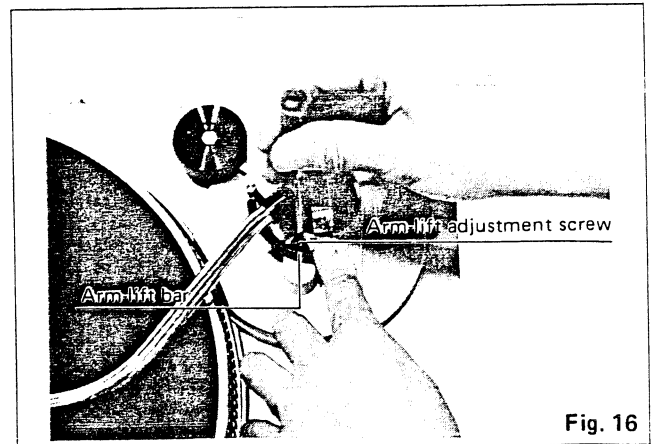

Fig. 16

Note:

As the adjusting screw has a hexagonal head, be sure to make the adjustment while depressing the arm lift, or the screw will not move freely. Also be sure that the hexagonal head retracts correctly into the arm lift when the latter is released.

Adjustment for automatic start position (See Fig. 18)

(remove the rubber cap.)

In cases where the stylus tip sets down outside of the record

—rotate clockwise.

In cases where the stylus tip sets down too far in the recorded groove

—rotate counterclockwise.

Adjustment for automatic return position (See Fig. 18)

(Remove the turntable mat.)

In cases where the tonearm tends to return before the playing has finished.

—rotate clockwise.

In cases where the tonearm fails to return after the last groove of the record has been played.

—rotate counterclockwise.

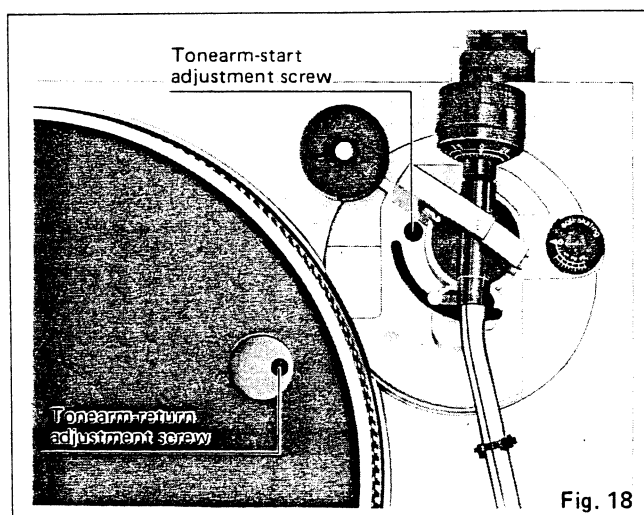

Fig. 18

Fine speed adjustment (See Fig. 19 and 20)

The strobe dots on the outer periphery of the turntable enable you to make a fine speed adjustment of +3.3% or -3.3%.

1. Set the speed control switch to the position "adj."
2. While turning the pitch control knob to the "+" side (or the "-" side), adjust to the degree at which the strobe dots on the upper stage (or lower stage) look as if they were stationary to obtain a pitch of +3.3% (or -3.3%).
3. Upon setting the speed control switch to the position "quartz", regular revolutions are available.

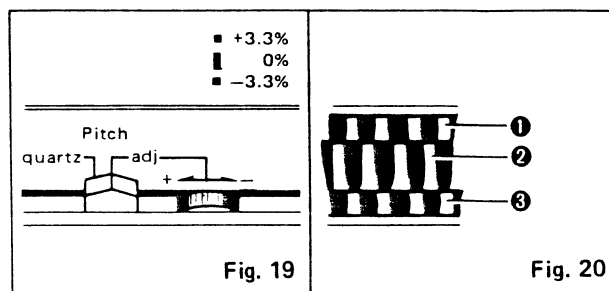

Fig. 19

Fig. 20

- 1 When the strobe dots at the upper stage appear stationary, the revolution is set at +3.3%.
- 2 At the quartz position, regular revolutions are available.
- 3 When the strobe dot at the lower stage appear stationary, the revolution is set at -3.3%.

Muting adjustment (See Fig. 21)

This unit employs a muting mechanism for eliminating the unpleasant noise produced when the stylus tip descends to or leaves the record. In cases where adjustments for the muting time are required, for example, after the arm lift height adjustment, etc., follow the procedures as given below.

If the signal of a record is not heard immediately after descent of the stylus tip onto the record, —turn the screw clockwise.

If any unpleasant noise is heard upon descent of the stylus tip onto the record, —turn the screw counterclockwise

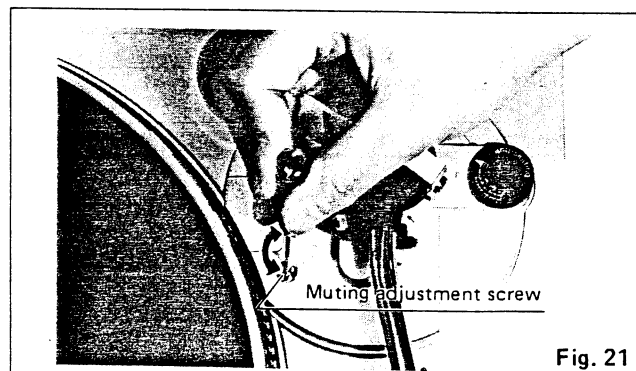

Fig. 21

■ JUSTIERUNGEN

Justierung der tonarmliftheöhe

Die Tonarmliftheöhe, d.h. der Abstand Zwischen Nadelspitze und Schallplattenoberfläche wenn der Lift-Schieber in der "▼"-Position steht, ist werkseitig auf 5–10 mm eingestellt worden. (Vgl. Abb. 15.)

Wenn Sie einen anderen Tonabnehmertyp verwenden, oder, wenn weitere Justierungen unbedingt nötig sind, nehmen Sie die Justierungen auf folgende Weise vor:

1. Stellen Sie den Drehzahl-Wahlschieber in die "•"-Position, um zu verhindern, daß sich der Plattenteller dreht.
2. Schwenken Sie den Tonarm gegen die Plattentellerachse.
Setzen Sie den Nadelschutz auf, damit die Nadelspitze vor Beschädigung geschützt wird.
3. Drehen Sie die Justierschraube im Uhrzeiger- oder Gegenuhrzeigersinn, währenddem Sie die Tonarmliftführung nach unten drücken. (Vgl. Abb. 16.)

Drehung im Uhrzeigersinn

–Der Abstand wird kleiner.

Drehung im Gegenuhrzeigersinn

–Der Abstand wird größer.

Anmerkung:

Da die Justierschraube einen Sechskantkopf hat, muß die Tonarmliftführung während dem Justieren unbedingt gedrückt gehalten werden, damit sich die Schraube leicht drehen läßt.

Vergewissern Sie sich, daß Sechskantkopf in die Tonarmliftführung zurückkehrt, wenn diese losgelassen wird.

Justierung des Tonarmaufsetzpunktes der Automatik (Vgl. Abb. 18).

(Die Gummikappe abnehmen)

Falls der Aufsetzpunkt außerhalb der Platte liegt.

–Im Uhrzeigersinn drehen.

Falls der Aufsetzpunkt im Wiedergabeteil der Schallplatte liegt.

–Im Gegenuhrzeigersinn drehen.

Justierung des Abschaltpunktes der Automatik (Vgl. Abb. 18.)

(Plattentellerauflage abnehmen.)

Falls der Tonarm zu früh zurückkehrt.

–Im Uhrzeigersinn drehen.

Falls der Tonarm nach Erreichen der Auslaufrille nicht zurückkehrt.

–Im Gegenuhrzeigersinn drehen.

Geschwindigkeits-Feineinstellung (Vgl. Abbs. 19, 20)

Die Stroboskoppunkte am Plattentellerrand ermöglichen die Feinregulierung der Drehzahl um +3,3% oder –3,3%.

1. Stellen Sie den Quarzregelung-Schalter in die "Adj." Position.

2. Regulieren Sie durch Drehen des Feineinstellknopfes in die "+"-Richtung (oder "-"-Richtung), bis die oberen (oder unteren) Stroboskoppunkte stillzustehen scheinen, und somit eine Drehzahl von +3,3% (oder –3,3%) erreicht ist.

3. Nach Umstellen des Quarzregelung-Schalter in die "quartz"-Position ist die genaue Drehzahl eingestellt.

Dämpfungsjustierung (Vgl. Abb. 21.)

Dieses Gerät ist mit einem Dämpfungsmechanismus zur Ausscheidung der unerwünschten Geräusche beim Absenken und Abheben der Nadelspitze ausgestattet.

In Fällen, wo eine Justierung der Dämpfungsdauer erforderlich ist, z.B. nach erfolgter Justierung der Tonarmliftheöhe usw., nehmen Sie die Justierung auf folgende Weise vor:

Falls die Wiedergabe nicht sofort nach erfolgtem Absenken der Nadelspitze auf die Schallplatte erfolgt:–**die Schraube im Uhrzeigersinn drehen.**

Falls störende Geräusche beim Absenken der Nadelspitze auf die Schallplatte gehört werden:–**die Schraube im Gegenuhrzeigersinn drehen.**

■ REGLAGES

Mise au point de la hauteur de l'élevateur du bras

La hauteur de l'élevateur du bras (distance entre l'extrémité de la pointe de lecture et la surface du disque, lorsque la manette de pose et de relevage du bras est à la position "▼") a été réglée en usine avant son départ sur approximativement 5 à 10 mm. (Voir Fig. 15.)

Pour l'utilisation des diverses cellules pick-up disponibles sur le marché ou lorsque des mises au point ultérieures sont particulièrement nécessaires, faire les réglages d'après ce qui suit:

1. Placer la manette sélectrice de vitesse sur la position "•" pour éviter la rotation du plateau.
2. Déplacer le bras de lecture vers le pivot central. Fixer le capot protecteur de la pointe de lecture, s'il en existe un, pour protéger l'extrémité de la pointe d'une éventuelle détérioration.
3. Tourner la vis de réglage dans le sens des aiguilles d'une montre ou dans le sens inverse, tout en abaissant l'élevateur du bras. (Voir Fig. 16.)

Rotation dans le sens des aiguilles d'une montre.

—La distance entre la surface du disque et l'extrémité de la pointe de lecture diminue.

Rotation dans le sens contraire des aiguilles d'une montre.

—La distance entre la surface du disque et l'extrémité de la pointe de lecture augmente.

Nota:

Comme la vis de réglage possède une tête hexagonale, s'assurer d'effectuer la mise au point tout en abaissant l'élevateur du bras, sinon la vis ne bougera pas librement. Vérifier que la tête hexagonale se retire correctement dans l'élevateur du bras quand ce dernier est libéré.

Mise au point pour une position de retour automatique (Voir Fig. 18.)

(Retirer le tapis du plateau de lecture.)

Dans le cas où le bras de lecture tend à revenir avant que l'audition ne soit terminée.

—Déplacer dans le sens des aiguilles d'une montre.

Dans le cas où le bras de lecture ne peut revenir en arrière après le dernier sillon du disque.

—Déplacer dans le sens contraire des aiguilles d'une montre.

Mise au point pour une position de marche automatique. (Voir Fig. 18.)

(Retirer le capuchon en caoutchouc.)

Dans le cas où la tête de la pointe de lecture s'abaisse en dehors du disque.

—Déplacer dans le sens des aiguilles d'une montre.

Dans le cas où la tête de la pointe de lecture s'abaisse trop loin du sillon enregistré.

—Déplacer dans le sens contraire des aiguilles d'une montre.

Réglage précis de la vitesse (Voir Figs. 19, 20)

Les points stroboscopiques sur la circonférence extérieure du plateau de lecture permettent un réglage précis de la vitesse de +3,3% ou de -3,3%.

1. Régler l'interrupteur de réglage de la vitesse sur la position "adj". (mise au point).
2. Tout en tournant la manette de réglage de précision de la vitesse du côté "+" (ou du côté "-"), mettre au point les points stroboscopiques sur l'étage supérieur (ou sur l'étage inférieur) qui ont l'air d'être stationnaires, pour obtenir une précision de la vitesse de +3,3% (ou -3,3%).
3. En réglant l'interrupteur de réglage de la vitesse sur la position "quartz", des rotations uniformes sont possibles.

Réglage de l'amortissement (Voir Fig. 21.)

Cet appareil utilise un mécanisme d'amortissement pour l'élimination des bruits déplaisants produits lorsque l'extrémité de la pointe de lecture s'abaisse sur le disque ou s'en relève.

Dans le cas où des mises au point seraient nécessaires, par exemple, après le réglage de la hauteur du souleveur du bras, etc., suivre les procédures données ci-dessous.

Si l'exécution du disque ne se fait pas entendre immédiatement après la descente de l'extrémité de la pointe de lecture sur le disque,—tourner la vis dans le sens des aiguilles d'une montre.

Si un bruit déplaisant est entendu lors de la descente de la tête de la pointe de lecture sur le disque,—tourner la vis dans le sens inverse des aiguilles d'une montre.

Schematic Diagram

(This schematic diagram may be modified at any time with the development of new technology.)

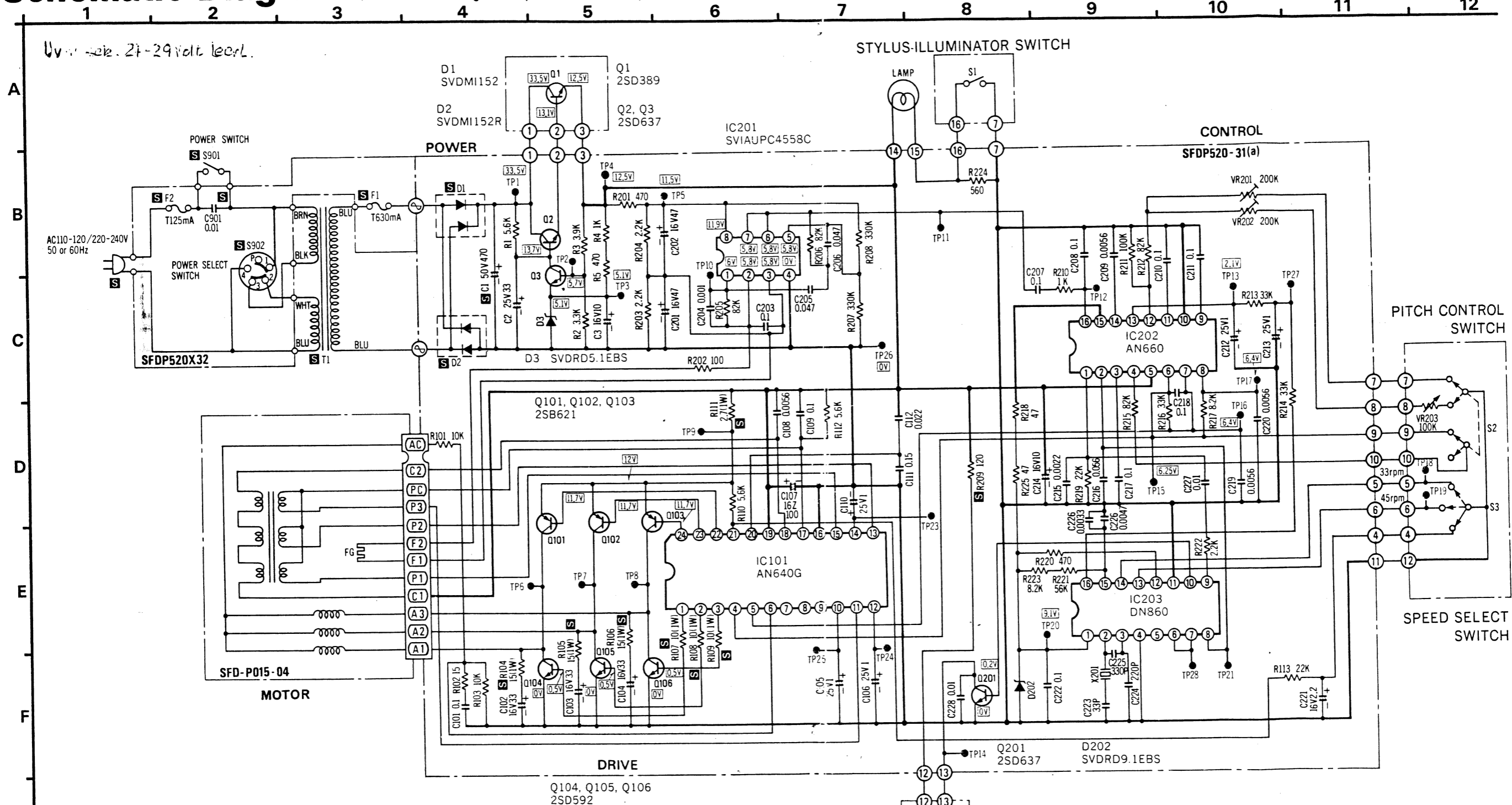

- Notes:**
1. S1: Stylus-illuminator switch in "OFF" position.
 2. S2: Pitch control switch in "Quartz" position.
 3. S3: Speed select switch in "OFF" position.
 4. S901: Power switch in "OFF" position.
 5. The voltage values are those measured on DC voltmeter at 33-1/3 r.p.m. For the voltage and waveform at each IC pin, refer to page 17.
 6. To represent transistors, Q is used instead of TR. (Ex. TR1 → Q1)
 7. indicates that only parts specified by the manufacturer be used for safety.

TERMINAL GUIDE OF TRANSISTOR AND IC

AN640G	DN860 AN660	SVIAPC4558C	2SD389	2SD637	2SB621 2SD592

REPLACEMENT PARTS LIST

- Notes:**
- Part numbers are indicated on most mechanical parts. Please use this part number for parts orders.
 - S** indicates that only parts specified by the manufacturer be used for safety.
 - SL-5300 (X) → [X] SL-5300 (E) → [E] SL-5310 (E) → [10E]
 SL-5300 (XAL) → [XAL] SL-5300 (XG) → [XG] SL-5310 (XG) → [10XG]
 SL-5300 (XGE) → [XGE] SL-5300 (XGF) → [XGF]

Ref. No.	Part No.	Part Name & Description
INTEGRATED CIRCUITS		
IC101 IC201 IC202 IC203	AN640G SVIUPC4558C AN660 DN860	Integrated Circuit Integrated Circuit Integrated Circuit Integrated Circuit
TRANSISTORS		
Q1 Q2, 3 Q101, 102, 103 Q104, 105, 106	2SD389A-Q 2SD637 2SB621-R 2SD592-R	Transistor Transistor Transistor (Use in ranks Q, R or S) Transistor (Use in ranks Q, R or S) } Use pair ranks
DIODES		
D1 D2 D3 D201 D202	S RVD10DC2 S RVD10DC2R SVDRD5.1EBS SVDGD4205ALC SVDRD9.1EBS	Rectifier Rectifier Diode, 5.1V Zener Light Emitting Diode Diode, 9.1V Zener
CRYSTAL		
X201	SVQU306115	4.19328MHz Oscillator
TRANSFORMER		
T1	S SLT48Q28E	Power Transformer
FUSES		
F1 F2	S XBA2C012TRO S XBA2C06TRO	125mA, Fuse 630mA, Fuse
SWITCHES		
S1 S2, 3 S5 S901 [X, XG, 10XG, XGF] S901 [XAL, XGE, E, 10E] S902	S SFDSHSW474 S SFDSHSW664 S SFDSHSW665 S SFDSA764039 S V-1A445 S SFDSHXW01317	Switch, Stylus-Illuminator Switch, Select Switch, Muting Switch, Power Switch, Power Switch, Power Source Selector
VARIABLE RESISTORS		
VR201, 202 VR203	EVLS6AA00B25 EVHX8AF15B15	200kΩ, Speed Control 100kΩ, Pitch Control
RESISTORS		
R1 R2 R3 R4 R5 R101 R102 R103 R104, 105, 106 R107, 108, 109	ERD25TJ562 ERD25TJ332 ERD25TJ392 ERD25TJ102 ERD25TJ471 ERD25TJ103 ERD25TJ150 ERD25TJ103 ERD25TJ103 ERG1ANJ150 ERG1ANJ100	Carbon, 5.6kΩ, 1/4W, ± 5% Carbon, 3.3kΩ, 1/4W, ± 5% Carbon, 3.9kΩ, 1/4W, ± 5% Carbon, 1kΩ, 1/4W, ± 5% Carbon, 470Ω, 1/4W, ± 5% Carbon, 10kΩ, 1/4W, ± 5% Carbon, 15Ω, 1/4W, ± 5% Carbon, 10kΩ, 1/4W, ± 5% Carbon, 15Ω, 1/4W, ± 5% Metallic, 15Ω, 1W, ± 5% Metallic, 10Ω, 1W, ± 5%

Ref. No.	Part No.	Part Name & Description
R110 R111 R112 R113 R202 R201 R203, 204 R205, 206 R207, 208 R209	ERD25TJ562 ERX1ANJ2R7 ERD25TJ562 ERD25TJ223 ERD25TJ101 ERD25TJ471 ERD25TJ222 ERD25TJ823 ERD25TJ334 ERD25TJ121	Carbon, 5.6kΩ, 1/4W, ± 5% Metallic, 2.7Ω, 1W, ± 5% Carbon, 5.6kΩ, 1/4W, ± 5% Carbon, 22kΩ, 1/4W, ± 5% Carbon, 100Ω, 1/4W, ± 5% Carbon, 470Ω, 1/4W, ± 5% Carbon, 2.2kΩ, 1/4W, ± 5% Carbon, 82kΩ, 1/4W, ± 5% Carbon, 330kΩ, 1/4W, ± 5% Carbon, 120Ω, 1/4W, ± 5%
R210 R211 R212 R213, 214 R215 R216 R217 R218 R219 R220	ERD25TJ102 ERD25TJ104 ERD25TJ823 ERD25TJ333 ERD25TJ823 ERD25TJ333 ERD25TJ822 ERD25TJ470 ERD25TJ223 ERD25TJ471	Carbon, 1kΩ, 1/4W, ± 5% Carbon, 100kΩ, 1/4W, ± 5% Carbon, 82kΩ, 1/4W, ± 5% Carbon, 33kΩ, 1/4W, ± 5% Carbon, 82kΩ, 1/4W, ± 5% Carbon, 33kΩ, 1/4W, ± 5% Carbon, 8.2kΩ, 1/4W, ± 5% Carbon, 47Ω, 1/4W, ± 5% Carbon, 22kΩ, 1/4W, ± 5% Carbon, 470Ω, 1/4W, ± 5%
R221 R222 R224	ERD25TJ563 ERD25TJ222 ERD25TJ561	Carbon, 50kΩ, 1/4W, ± 5% Carbon, 2.2kΩ, 1/4W, ± 5% Carbon, 560Ω, 1/4W, ± 5%
CAPACITORS		
C1 C2 C3 C101 C102, 103, 104 C105, 106 C107 C108 C109 C110	ECEB1HS471 ECEA1VS330 ECEA1HS100 ECQM1H104KZ ECEA1CS330	Electrolytic, 470μF, 50V Electrolytic, 33μF, 35V Electrolytic, 10μF, 50V Polyester, 0.1μF, 50V, ±10% Electrolytic, 33μF, 16V
C111 C112 C201, 202 C203 C204 C205, 206 C207 C208 C209 C210, 211 C212, 213 C214 C215 C216 C217, 218 C219, 220	ECQ1H154KZ ECQM1H223KZ ECEA1ES470 ECKD1E104ZFZ ECQM1H102KZ ECQM1H473KZ ECQM1H104KZ ECKD1E104ZFZ ECQM1H562KZ ECQM1H104KZ ECSF25E12EN ECEA1HS100 ECQM1H222KZ ECQM1H563JZ ECQM1H104KZ ECQM1H562KZ	Tantalum, 1μF, 25V Electrolytic, 100μF, 16V Polyester, 0.0056μF, 50V, ±10% Polyester, 0.1μF, 50V, ±10% Tantalum, 1μF, 25V Polyester, 0.15μF, 50V, ±10% Polyester, 0.022μF, 50V, ±10% Electrolytic, 47μF, 25V Ceramic, 0.1μF, 35V, ±10% Polyester, 0.001μF, 50V, ±10% Polyester, 0.047μF, 50V, ±10% Polyester, 0.1μF, 50V, ±10% Polyester, 0.1μF, 35V, ±10% Polyester, 0.0056 F, 50V, ±10% Polyester, 0.1μF, 50V, ±10% Tantalum, 1μF, 25V Electrolytic, 10μF, 50V Polyester, 0.0022μF, 50V, ±10% Polyester, 0.056μF, 50V, ± 5% Polyester, 0.1μF, 40V, ±10% Polyester, 0.0056μF, 50V, ±10%
C221 C222 C223 C224 C225 C226	ECEA2AS2R2 ECKD1E104ZFZ ECCD1H330K ECCD1H221K ECCD1H331K ECQS1472K ECQM1H332KZ ECQM1H103KZ ECQE2A103MZ	Electrolytic, 2.2μF, 100V Ceramic, 0.1μF, 35V, ±10% Ceramic, 33pF, 50V, ±10% Ceramic, 220pF, 50V, ±10% Ceramic, 330pF, 50V, ±10% Polystyrene, 0.0047μF, 125V, ±20% Ceramic, 0.0033μF, 50V, ±20% Ceramic, 0.01μF, 50V, ±20% Polyester, 0.01μF, 250V, ±20%
C227, 228 C901[X, XG, 10XG, XGF] C901[XAL, XGE, E, 10E]	ECKDHS103SE2	Polyester, 0.01μF, 250V, ±20%

Printed Circuit Board

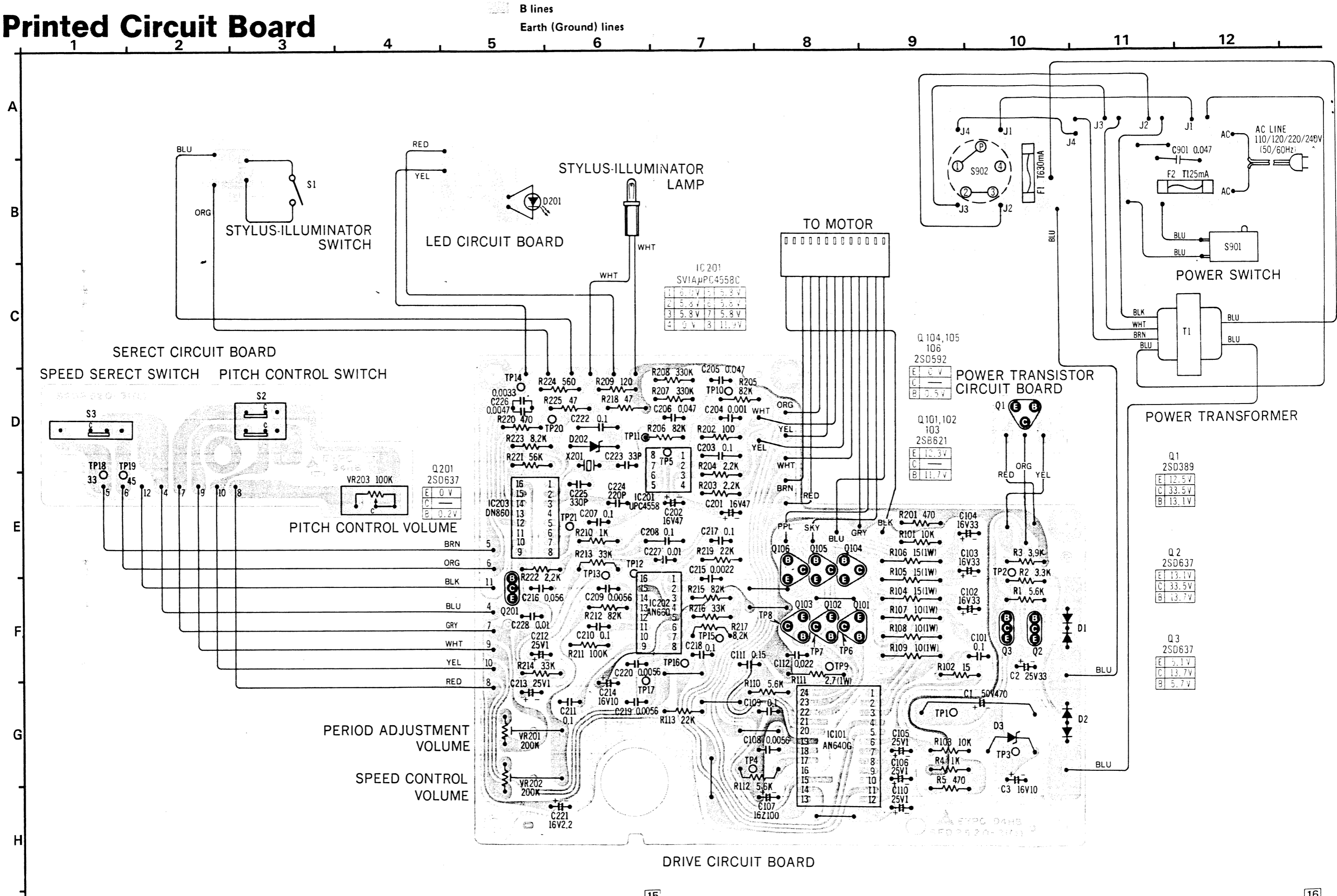

B lines
Earth (Ground) lines

IC 201
SV1A μ PC4558C

1	6.0V	5.3V
2	5.3V	5.3V
3	5.8V	5.8V
4	0V	11.9V

Q 104, 105
106
2SD592

E	0V
C	-
B	2.5V

Q 101, 102
103
2SB621

E	13.3V
C	-
B	11.7V

Q1
2SD389

E	12.5V
C	33.5V
B	13.1V

Q 2
2SD637

E	13.1V
C	33.5V
B	13.7V

Q 3
2SD637

E	3.1V
C	13.7V
B	5.7V

Adjustment Points of Electrical System

NOTE: Make the following adjustments after replacing parts such as IC's, transistors, diodes, etc.

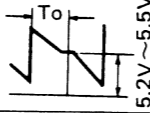
No.	Adjustment	Connection for measurement	Part adjusted	Adjusting procedure
1.	(TRACKING)	(Oscilloscope) ⊕ - TP26 ⊖ - Earth ⊕ TP21	VR201	 Set power switch ON to rotate the turntable. Then adjust VR201 so that To is 6 ~ 7 msec. at 33 r.p.m.
2.	(SPEED)		VR202	Set speed volume (VR203) to the central point, and then adjust VR202 so that turntable is stationary in stroboscope light. Note) At that time, quartz should be OFF.

Justierungspunkte des elektrischen Systems

BEMERKUNG: Nehmen Sie die folgenden Justierungen nach erfolgtem Austausch von Teilen, wie IC's, Transistoren, Dioden, usw. vor.

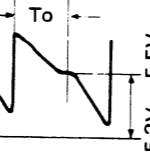
Nr.	Justierung	Anschluß für Messung	Teil zu justieren	Justierungsverfahren
1.	Abgleich (TRACKING)	(Oszillograph) ⊕ TP26 ⊖ - Erdung ⊕ TP21	VR201	 Hauptschalter auf ON stellen, um Plattenteller zu drehen. Dann VR201 so justieren, daß To unnerhalb von 6-7 msec. bei 33 U/m bleibt. Anm.: dabei soll Quarz ON sein.
2.	Geschwindigkeit (SPEED)		VR202	Geschwindigkeitsregler (VR203) auf die Mitte stellen, dann VR202 so einstellen, daß Stroboskop am Plattenteller stehenbleibt. Anm.: Dabei soll Quarz Off sein.

Points de réglage du système électrique.

NOTA: Réaliser les mises au point suivantes après le remplacement de certains éléments tels que circuits intégrés, transistors, diodes, etc.

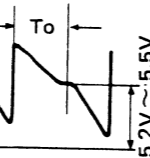
No.	Réglage	Branchement pour la mesure	Elément à régler	Procédé de réglage
1.	Réglage exact (TRACKING)	(Oscilloscope) ⊕ - TP26 ⊖ - Terre ⊕ TP21	VR201	 Placer le commutateur d'alimentation sur ON (marche) pour faire tourner le plateau du tourne-disque. Puis régler VR201 de telle sorte que To soit de 6 à 7msec.
2.	Vitesse (SPEED)		VR202	Placer le volume de la vitesse (VR203) en position centrale et régler VR202 de telle sorte que le plateau du tourne-disque apparaisse stationnaire dans la faisceau du stroboscope. Note: A cette étape, le quartz doit être sur OFF (arrêt)

■ TROUBLE SHOOTING

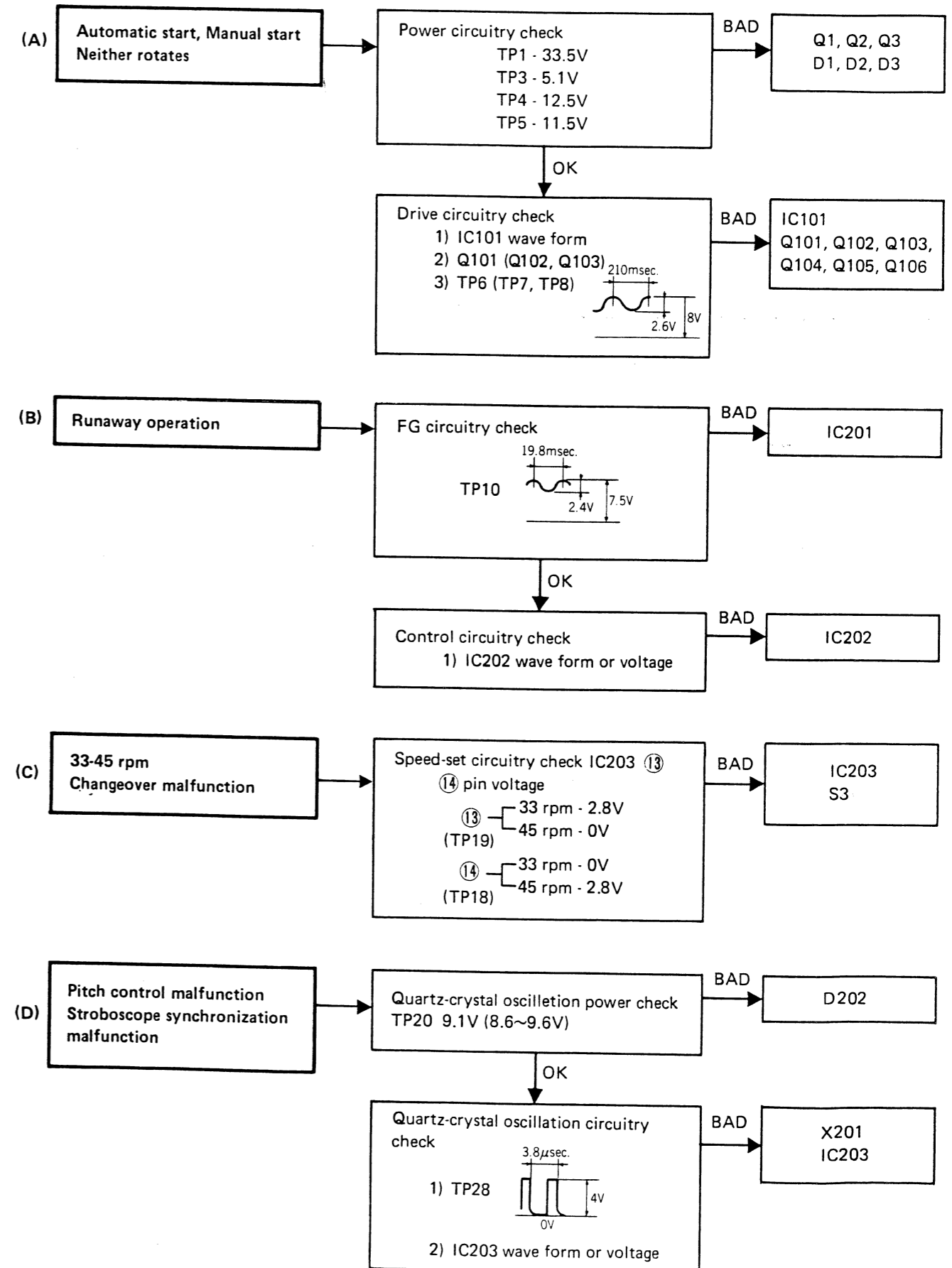

■ REFERENCE VOLTAGE AND WAVEFORM AT EACH IC PIN AND TEST POINT

IC101 (AN640G)

①		⑩		⑰	8.3 V	⑳	
②		⑬		⑱		㉑	
③		⑭		㉒		㉓	
⑥		⑮		㉔			

IC202 (AN660)

①		⑦	6.4 V	⑪		⑬	2.1 V	⑯	
②		⑧	6.4 V	⑫	2.1 V	⑭			

IC203 (DN860)

①	9.1 V	③		⑨		⑬	33 r.p.m.	2.8 V	⑮	
							45 r.p.m.	0 V		
②		⑥		⑩		⑭	33 r.p.m.	0 V	⑯	
							45 r.p.m.	2.8 V		

TESTPOINT (TP)

TP1	33.5 V	TP6		TP10		TP12	IC202 ⑯	TP17	IC203 ⑧
TP2	5.7 V	7		TP11		TP13	2.1 V	TP18	IC203 ⑭
TP3	5.1 V	8				TP14		TP19	IC203 ⑬
TP4	12.5 V					TP15	6.25 V	TP20	9.1 V
TP5	11.9 V	TP9	12 V			TP16	IC202 ⑦	TP21	IC203 ⑧

■ BLOCK DIAGRAM

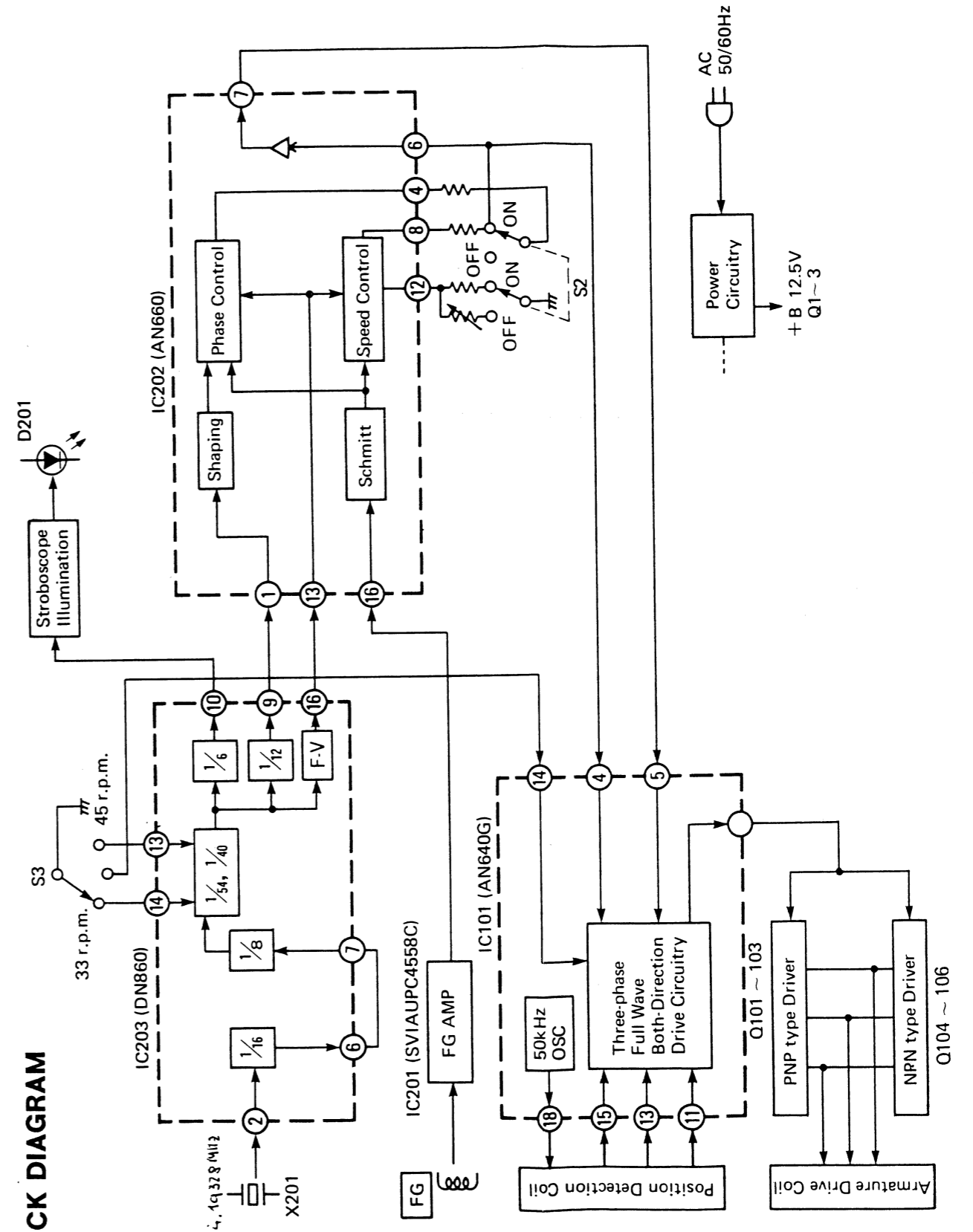

■ EXPLODED VIEWS

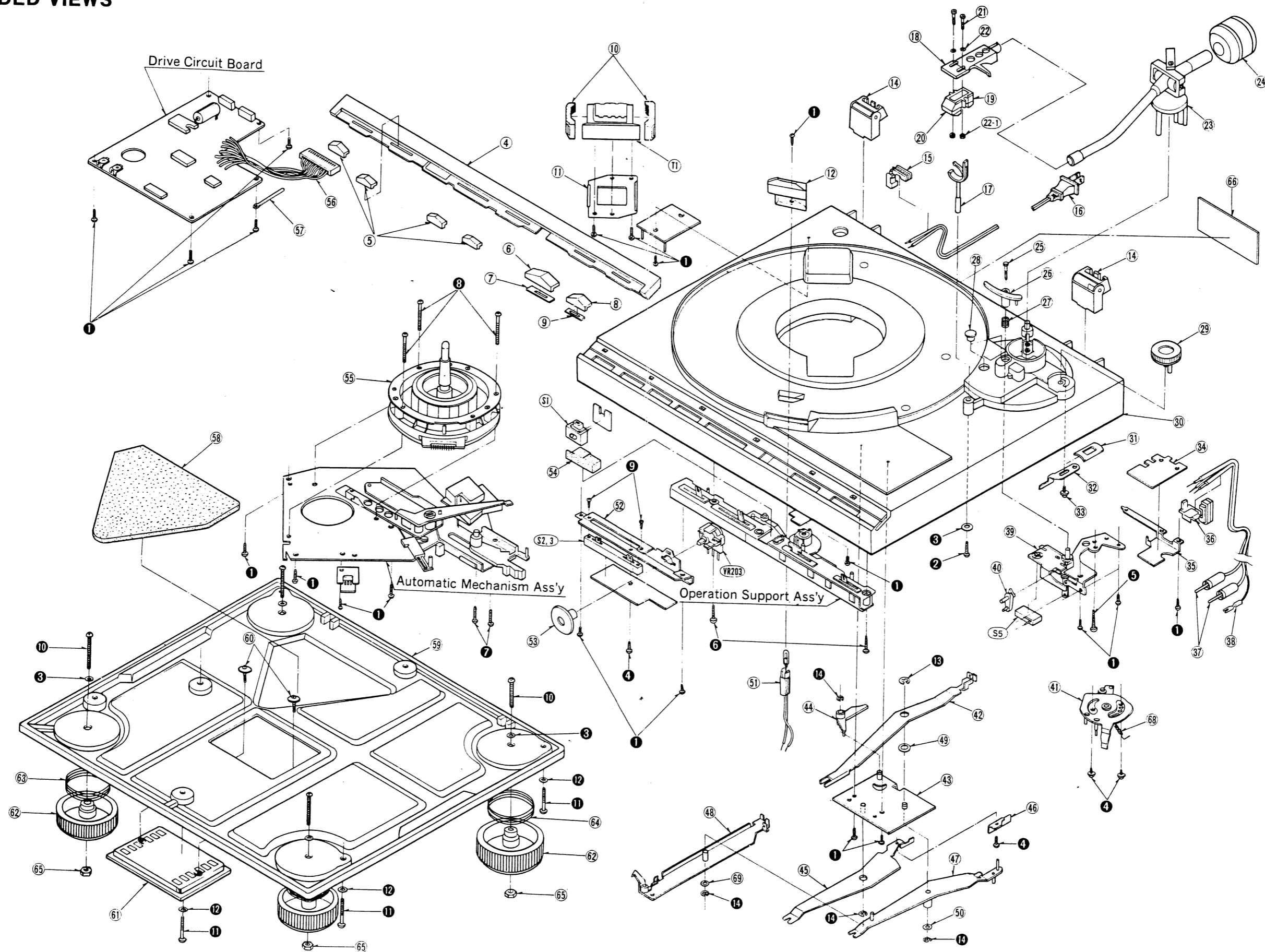

REPLACEMENT PARTS LIST

- Notes:**
- Part numbers are indicated on most mechanical parts. Please use this part number for parts orders.
 - S** indicates that only parts specified by the manufacture be used safety.
 - SL-5300 (X) → [X] SL-5300 (XG) → [XG] SL-5300 (XGE) → [XGE] SL-5310 (E) → [E]
SL-5300 (XAL) → [XAL] SL-5300 (XGF) → [XGF] SL-5300 (E) → [E] SL-5310 (XG) → [XG]

Ref. No.	Part No.	Part Name & Description
CABINET and CHASSIS PARTS		
1	SFAD520-31E	Dust Cover
2	SFTG320-01	Turntable Mat
3	SFTE520-31A	Turntable
4 [X, XAL, XGE, E, XG, XGF]	SFKK530-31	Panel Front
4 [10E, 10XG]	SFKK531P31	Panel, Front
5	SFKT520-33	Knob, Select
6	SFKT520-31	Knob, Operation
7	SFXW212-02	Washer, Operation Knob
8	SFKT520-32	Knob, Cueing
9	SFXW212-01	Washer, Cueing Knob
10	SFGC520-31	Cushion, Power Transformer
11	SFUP520-31	Plate, Power Transformer
12	SFUM520-31	Cover, Neon
14	SFAT301-01A	Hinge
15	SFUM190-12	Bushing, AC Cord
15 [except XAL]	SFUM190-11	Bushing, AC Cord
15 [XAL]	SFUM190-12	Bushing, AC Cord
16 [X, E, 10E, XG, 10XG, XGF]	RJA23ZC-K	AC Cord
16 [XAL]	QFC1208M	AC Cord
16 [XGE]	RJA45ZC-K	AC Cord
17	SFKU212-01E	Arm Rest
18	SFPC31001K	Headshell
19 [except XGE, XGF]	EPC206CK	Cartridge
20 [except XGE, XGF]	EPS206ED	Stylus
21 [except XGE, XGF]	SFCZV8801	Screw, Cartridge
22 [except XGE, XGF]	SFPEN3302	Nut, Cartridge
22-1 [except XGE, XGF]	SFPEW9601	Washer, Cartridge
23	SFPAM51001K	Tone Arm
24	SFPWG51001K	Balance Weight
25	SFXG829-1	Screw, Tone Arm Lift Adjustment
26	SFPR5100K	Lift Ass'y
27	SFQA829-03	Spring, Lift Ass'y
28 [X, XAL, XGE, E, XG, XGF]	SFGK132-01	Cap, Rubber (Silver)
28 [10E, 10XG]	SFGK133S01	Cap, Rubber (Black)
29	SFPJK19004	Knob, Anti-skate Force Control
30 [X, XAL, XGE, E, XG, XGF]	SFAC520-31	Cabinet (Silver)
30 [10E, 10XG]	SFAC521P31	Cabinet (Black)
31	SFQP212-02	Supporter, Anti-skate Force Control
32	SFUP212-02	Plate, Anti-skate Force Control
33	SFXG212-04	Screw, Anti-skate Force Control
34	SFDP520-35	P.C.B., Phono Cord
35	SFUP320-01	Plate, Shield
36	SFUM212-08	Clamper, Phono Cord
37	SFDH212-01	Phono Cord
38	SFEL028-01E	Ground Wire
39	SFUP520-32A	Bracket, Lift Ass'y
40	SFUM212-01	Cam, Cueing
41	SFUP520-38A	Tone Arm Fixing Plate Ass'y
42	SFUP212-04	Lever, Cueing
43	SFUK230-02E	Plate, Cueing
44	SFUM230-07	Lever, Stop
45	SFUP222-01	Lever, Start
46	SFQP230-01	Supporter, Start Lever
47	SFUP230-04E	Lever, Select
48	SFUP230-03A	Lever, Searching
49	SFXW190-22	Washer, Cueing Lever
50	XWE4D8BW	Washer, Select Lever
51	SFDN520-31E	Lamp Ass'y
52	SFUP520-36	Plate, Selector Switch
53	SFKT212-02	Knob, Pitch Control
54	SFGZ520-31	Rubber, Switch
55	SFM2520-31Z	Stator Frame Ass'y
56	SFDJ520-31E	Connector, Motor P.C.B.

Ref. No.	Part No.	Part Name & Description
57	SXE513	Clamper, Cord
58	SFGZ320-01	Rubber, Bottom Board
59	SFAU320-01	Bottom Board
60	SFXG132-02	Screw, Cover
61	SFUM320-02	Cover, Bottom Board
62	SFGA520-31	Audio Insulator
63	SFQC200-02	Spring, (Front) Audio Insulator
64	SFQC320-01	Spring, (Rear) Audio Insulator
65	XNG3HS	Nut, Audio Insulator
66 [X, XG, XGF]	SFNN530X31	Name Plate
66 [XAL, XGE]	SFNN530G31	Name Plate
66 [E]	SFNN530S31	Name Plate
66 [10XG]	SFNN531P31	Name Plate
66 [10E]	SFNN531S31	Name Plate
68	SFSP19004	Spring, Anti-skate Force Control
69	XWE4D8BW	Washer, Searching Lever
OPERATION SUPPORT ASS'Y		
71	SFUM230-02	Plate, Repeat
72	SFUM212-02	Plate Operation
73	SFYB5-32	Ball, Slider Ass'y
74	SFQA130-11	Spring, Slider Ass'y
75	SFUM230-01E	Selector, Slider Ass'y
76	SFQS230-01	Selector, Rod
77	SFUM212-03E	Slider Ass'y (A)
78	SFUM230-04	Cam, Repeat
79	SFUP212-20E	Slider Ass'y (B)
80	SFUM230-03E	Repeat Ass'y.
81	SFUK230-01E	Operation Support Ass'y
82	SFXW170-02	Washer, Operation Support Ass'y
AUTOMATIC MECHANISM ASS'Y		
85	SFUC320-11E	Actuating Plate Ass'y
86	SFUM230-12	Index Plate
87	SFQS230-11	Spring, Index Plate
88	SFXW831-5	Washer, Index Plate
89	SFUB230-11A	Operating Plate Ass'y
90	SFXW130-13	Washer, Operating Plate Ass'y
91	SFXW623-02	Washer, Operating Plate Ass'y
92	SFUM222-14	Cover, Switch
93	SFUM222-15	Plate, Switch
94	SFUK320-11E	Automatic Mechanism Ass'y
95	SFUM222-13	Plate, Stop
96	SFQS222-12	Spring, Stop Plate
97	SFQS222-11	Spring, Supporter
98	SFUM222-11	Supporter, Gear Setting
99	SFUG190-22E	Main Gear Ass'y
100	SFXW890B01	Washer, Main Gear Ass'y
101	SFUM230-14	Pin, Switch Supporter
102	SFQH130-14	Spring, Switch Supporter
103	SFUM230-13E	Supporter, Switch
104	SFUM222-16	Lever, Switch
105	SFUM230-11	Plate, Searching
106	SFQH910-11	Spring, Plate
SCREWS and CIRCLIPS		
①	XTN3+10B	Screw
②	XTN3+14B	Screw
③	XWG3	Washer
④	XTN3+8B	Screw
⑤	XTN4+16B	Screw
⑥	XTN3+20B	Screw
⑦	XTN3+35B	Screw
⑧	XTN3+30B	Screw
⑨	XSN2+4FN	Screw
⑩	XSN3+18S	Screw
⑪	XTN3+20BFZ	Screw
⑫	XWG3FZ	Washer
⑬	XUC5FT	Circlip
⑭	XUC3FT	Circlip
⑮	XTV3+35C	Screw
⑯	XTV3+10C	Screw

EXPLODED VIEWS

OPERATION SUPPORT ASS'Y

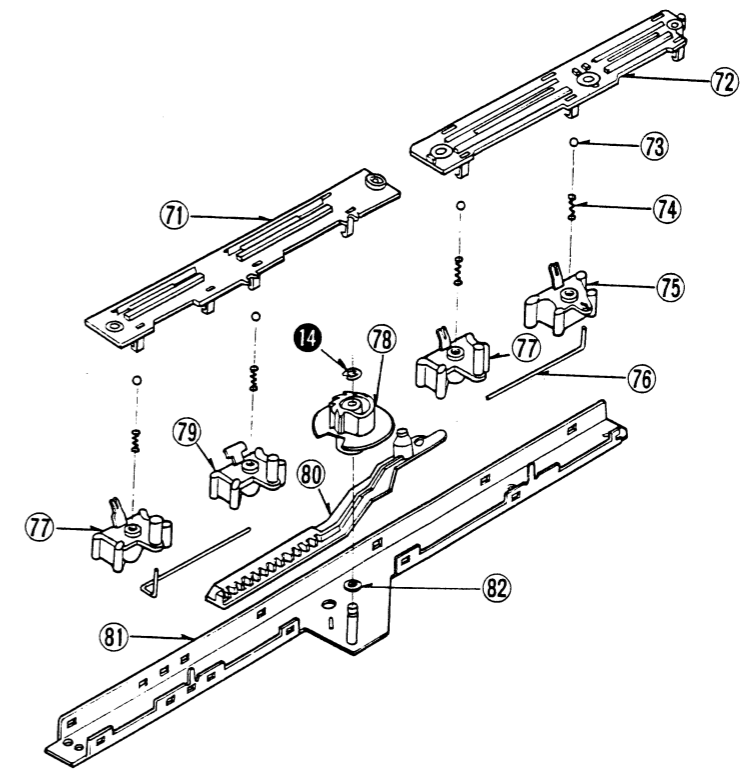

AUTOMATIC MECHANISM ASS'Y

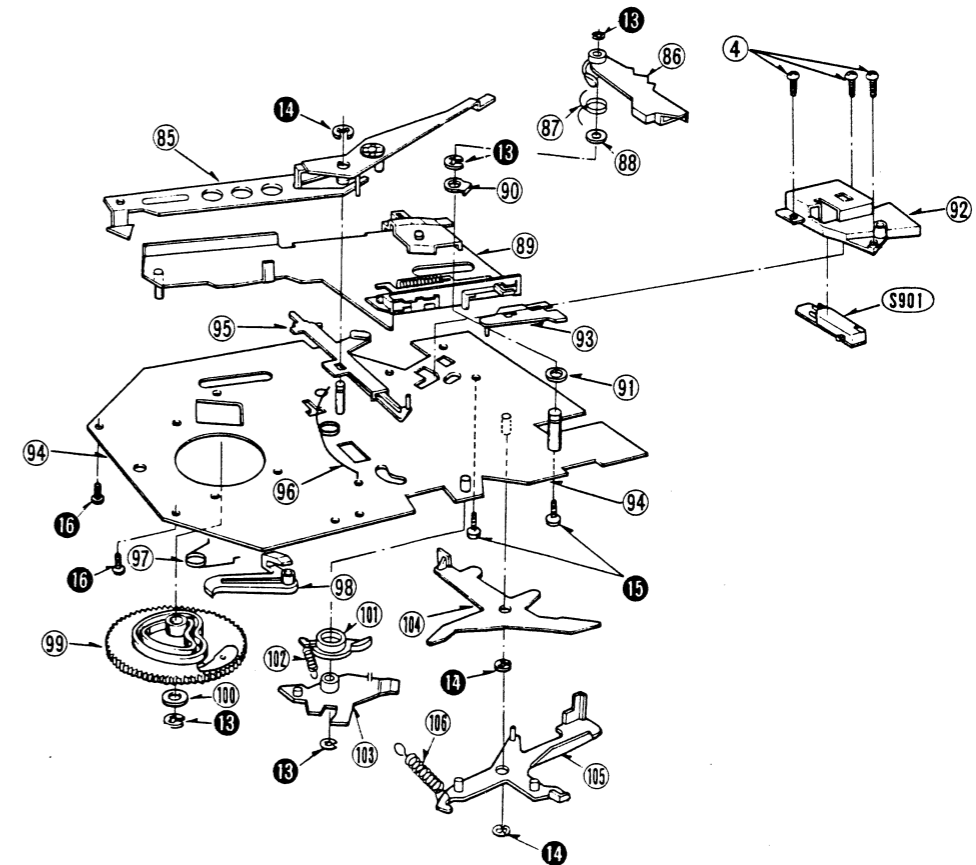

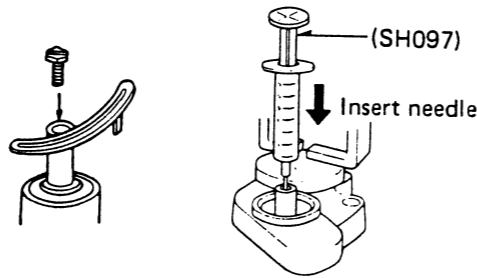
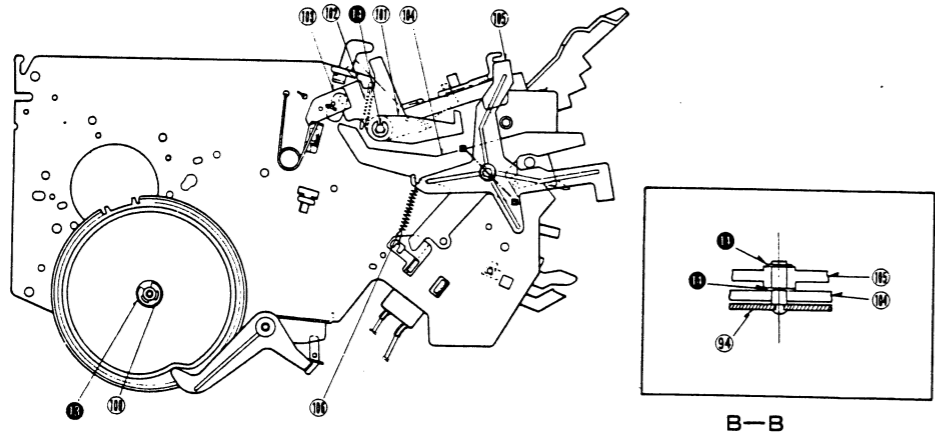
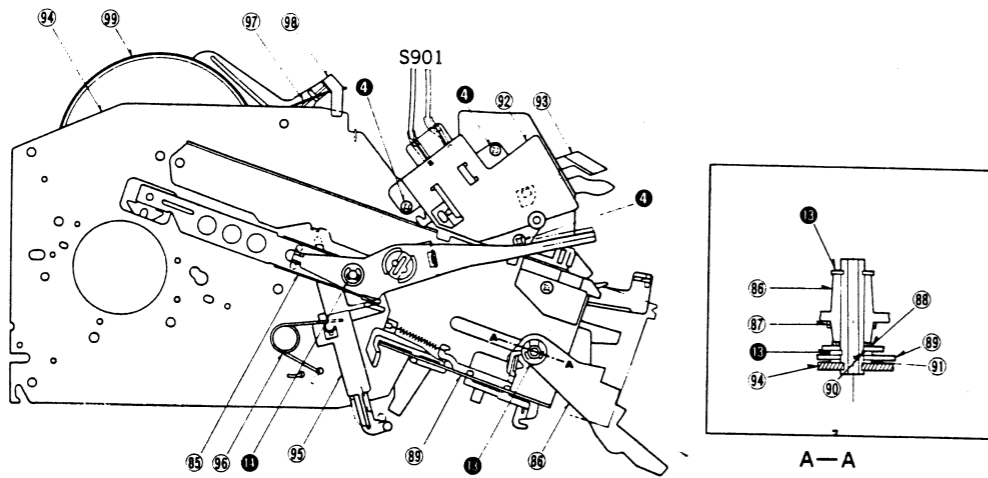

How to Inject Silicon Oil

After prolonged use the tone arm set down time may become too rapid in such rare case cueing oil should be added.

Please follow these instructions for applying the silicon oil:

1. Remove the arm height adjust screw to detach the arm lift
2. Insert the needle of the injector into the cylinder of the arm lift shaft and inject a small amount of silicon oil.
3. Slowly remove the injector.
4. Re-install arm lift bar and attach the arm height adjust screw.
5. Adjust the arm lift height.
(Refer to the adjustment procedure)

REPLACEMENT PARTS LIST.

Notes: SL-5300 (X) → [X] SL-5300 (E) → [E] SL-5310 (E) → [10E]
 SL-5300 (XAL) → [XAL] SL-5300 (XG) → [XG] SL-5310 (XG) → [10XG]
 SL-5300 (XGE) → [XGE] SL-5300 (XGF) → [XGF]

Ref. No.	Part No.	Part Name & Description
ACCESSORIES		
A1	SFNU530X31	Instruction Book
A2	SFWE212-01	Adaptor, 45 r.p.m.
A3	SFPEN3302	Nut, Cartridge
A3-1	SFPEW9601	Washer, Head Shell
A3-2	SFCZY8801	Screw, Cartridge
A3-4	SFYF05A06	Polyethylene Bag
A4	SFKO135-01E	Overhang Gauge
A5	SFPZB3501	Shell Weight
PACKING PARTS		
P1 [X, XAL, XGE, E, XG]	SFHP530X31	Carton
P1 [10E, 10XG]	SFHP531S31	Carton
P1 [XGF]	SFHP530J31	Carton
P2	SFHH320-01	Pad, Front
P3	SFHH320-02	Pad, Rear
P4	SFHD230-01	Pad, Top
P5	SFHD520-31	Pad, Turntable
P6	SFHH212-03	Parts Box
P7	SFHD212-03	Pad, Top, Parts Box
P8	SFYC22A30	Polyethylene Cover, Parts Box
P9	SFYF60X60	Polyethylene Cover, Player Unit
P9-1	SFYH60X60	Polyethylene Cover, Dust Cover
P9-2	SFYH40X45	Polyethylene Cover, Turntable
P9-3	SPP189	Polyethylene Bag, Cord

PACKINGS

